

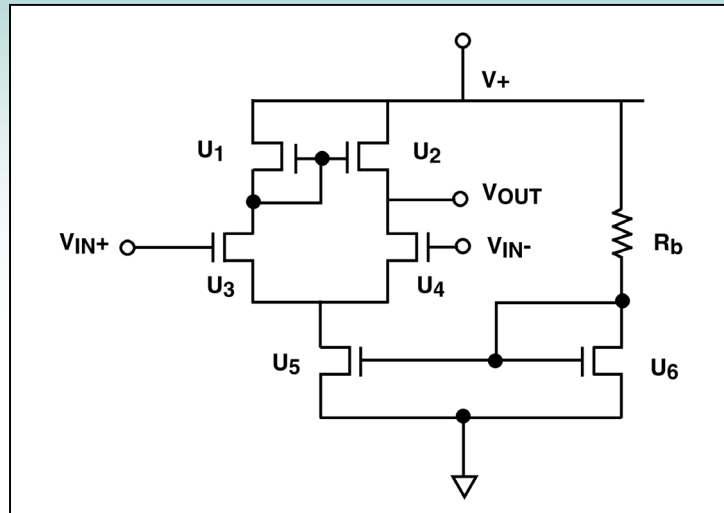

**+/-0.1V Differential Amplifier Circuit using Zero Threshold EPAD MOSFETs**



**Description**

This circuit presents a differential amplifier using Zero Threshold EPAD MOSFETs that operates on +/- 0.1V supplies. The schematic diagram is for a single amplifier stage. A second amplifier stage can be added to increase gain. This differential amplifier has high input impedance and relatively low gain and bandwidth, with one stage DC voltage gain of approximately 20, and two-stage DC voltage gain of 240. Quiescent current drain is 3.8  $\mu$ A for stage 1 at a power dissipation of 752 nW. The second amplifier stage benefits from using the same bias circuit as stage 1, without requiring additional U6 and Rb bias circuitry and associated current drain (The second stage can be biased with U5 gate at second stage connected to the gate terminal of U5 in stage 1). The quiescent current for a second amplifier stage is 1.98  $\mu$ A, which results in 397 nW of operating power. A third amplifier stage can be added to boost the DC gain to over 2500, at added circuit complexity and associated cost. This differential amplifier was evaluated for DC performance, while other performances such as frequency responses of this circuit have not yet been evaluated.

**Recommended Components**

- U1: 1/4 ALD110800      U2: 3 x 1/4 ALD110800 (3 ALD110800 connected in parallel)
- U3: 1/4 ALD110800      U4: 1/4 ALD110800
- U5: 1/4 ALD110800      U6: 2 x 1/4 ALD110800      Rb: 184 KOhm

**Other Related Circuit Ideas**